

Kodak 9000
Extraoral Imaging System

3D
Panoramic
Cephalometric

Innovation, in reach





Innovation made simple

We believe in innovation. We always have. In fact, our products have consistently distinguished themselves as groundbreaking solutions to real challenges.

Nevertheless, innovation alone won't do. Products must also be easy to understand and operate. Consequently, our design philosophy has always emphasized a commitment to practical ingenuity. In other words, we make sure innovation remains simple, while staying focused on the evolving needs of modern dentistry.

Today's practitioner requires diagnostic tools that are complete and effective. This was our inspiration in creating the Kodak 9000 system, the answer to the diagnostic needs of dentists, endodontists, periodontists, orthodontists, and maxillo-facial surgeons alike.

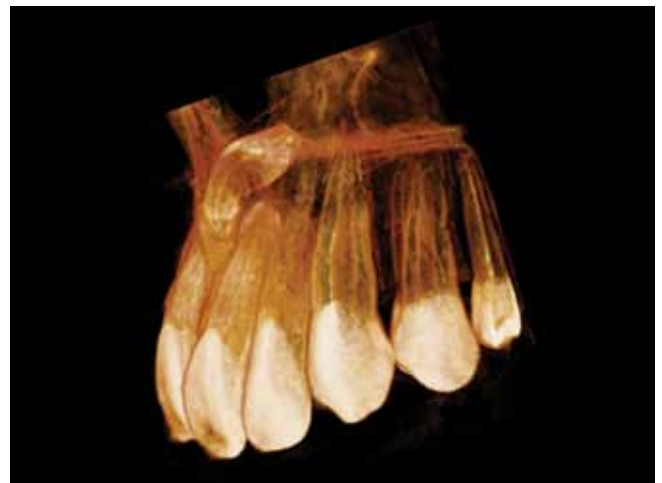
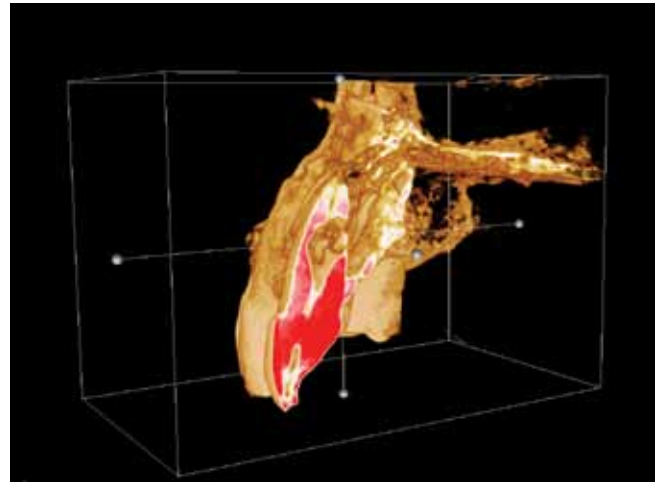

A three-in-one solution

One unit for all your diagnostic needs

With the ability to blend three technologies into one, the Kodak 9000 system is the multi-faceted solution to fit all practitioners' needs. It's the ideal and complete diagnostic tool that incorporates cutting-edge panoramic, cephalometric and 3D imaging.



Panoramic imaging

Produces complete dentition overview, the ideal first step before treatment

- Adjustable focal trough
- Easy and precise positioning
- User-friendly interface

Cephalometric imaging

Provides an array of projections and software functions for cephalometric analysis

- "One shot" technology
- High quality images
- Productivity enhancement
- Compact and convenient design
- Automatic landmark tracings
- Multiple cephalometric formats





3D imaging

Yields anatomically correct three-dimensional images directly onscreen



- Low radiation exposure
- Affordable, in-clinic 3D imaging
- High resolution
- Easy to install and to operate

The keys to the KODAK 9000 System

Innovation and simplicity

With the Kodak 9000 system, technology and innovation do not come at the expense of ease of use. A user-friendly design, dedicated application sensors are all aspects of a system that has been conceived to help improve comfort and effectiveness. The easy to use software platform is perfect for 2D and 3D images.

Superb image quality

The technologies employed are designed to deliver maximum image quality. The unit features a high frequency generator, an adjustable focal trough, "one shot" cephalometric capability, and ultra-high resolution 3D imaging. In other words, in each mode, high-end technology yields optimized results and security.

Good economic sense

Providing exceptional value for the money, the Kodak 9000 system makes 3D imaging accessible now more than ever before. It saves time, improves patient treatment, enhances your communication and enhances patient care. The return on investment from a device boasting so many innovations is immediately measurable.

3D benefits everyone

3D imaging can finally be your reality.

Perform 3D exams quickly and easily in your very own practice. Not only is the unit affordably priced, it's easy to use and to integrate. Furthermore, with low dose* radiation exposure, it's designed for daily use by both generalists and specialists alike. The Kodak 9000 3D gives you the power to visualize the patient accurately as they appear in nature.



Accurate, safe, and simple

The advantage of 3D localized views

The Kodak 9000 3D system boasts a localized field of view for high resolution images and voxel size. It provides a higher level of detail for single teeth, making it ideal for most local dental examinations, even the most demanding ones, such as endodontics and single implants.

The security of low-dose 3D imaging

Furthermore, with localized viewing, capture and exposure are confined to the local region of interest, thereby respecting the radiographic principle of ALARA (As Low as Reasonably Achievable). The average delivered dose for a single 3D exam performed with the Kodak 9000 system represents one to three days of natural daily exposure. More significantly, it represents ten to thirty times less exposure than some competing 3D systems. In essence, while improving image quality, localized 3D images also provide better protection for patients.

Flexible 3D programs

For cases that involve larger areas, the 3D stitching program allows you to combine up to three volumes into a single one. From local exams to full-arch exams, the Kodak 9000 3D system gives you the ability to select the most appropriate volume size for your diagnostic needs.

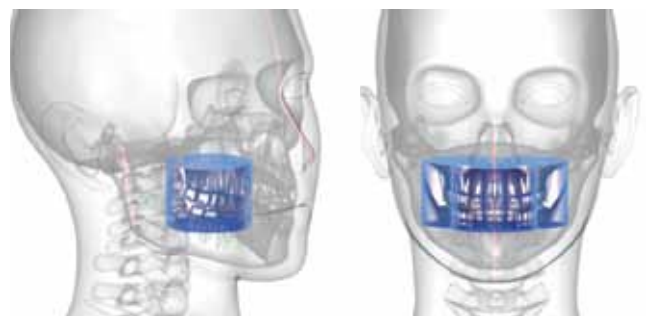

	Effective dose μSv	Equivalent daily effective dose (2400 $\mu\text{Sv}/\text{year}$)
Digital panoramic*	7 to 22	1 to 3 days
3D exam performed with Kodak 9000 3D system*	5 to 19	1 to 3 days
3D exam performed with competing 3D systems**	68 to 600	10 to 91 days

* Sources: Institut de la Radioprotection et de la Sûreté Nucléaire (IRSN) – Rapport 2008-07

** Sources: Ludlow JB, Dosimetry of CBCT Units for Oral and Maxillofacial Radiology

Select the most appropriate volume size for your diagnostic needs: Focused field of view for local exams, or extended field of view for full-arch exams.

3D can be simple

3D is easy to adopt

In less than two minutes you can acquire a dynamic 3D exam and visualize all the information that you need. 3D information for implantology and surgery can improve treatment outcomes, thus helping you reduce treatment time and the number of treatment visits. In diagnosis, you can obtain complementary information while in your clinical setting, allowing you to make the right decision on the spot.



3D is easy to use

The Kodak 9000 3D system features a streamlined user-interface and computer-controlled system, so performing a 3D exam is quick and simple. Patient positioning is facilitated by a unique bite block and set of lateral holders. You can choose the region of interest on your computer and the device positions itself there, automatically. A laser beam then allows you to adjust positioning.



New, confident diagnoses

A new perspective

The Kodak 9000 3D system gives you a new way of looking at dental structures and pathologies. You get all your information more clearly and all the angles and slices you need within the volume acquired.

Improved precision

With 3D imaging, you obtain exact visualization of dental structures in their actual spatial representation. Images are displayed in axial, coronal, sagittal, and custom slices. Meanwhile, the three-dimensional reconstruction provides a reassuring and exact 1:1 scale. This "true to life" view of dental structures unquestionably facilitates effective communication.

3D, the perfect complement

3D imaging takes nothing away from the usefulness of traditional 2D imaging. On the contrary, they are perfectly complementary. The panoramic and cephalometric image provide a global view/image while 3D goes into precise tooth detail, delivering information to refine your diagnosis.



Capture anatomically correct information to assist in diagnosis and treatment planning.



Above: Initial 2D panoramic exam shows two upernumerary teeth in maxillary anterior.

Right: Three-dimensional volumetric view and sagittal view show precise labial location of supernumerary tooth with no resorption of the central incisor root.

New technology, new applications

You can use your Kodak 9000 3D system for an array of applications, including: endodontics, implantology, surgery, fracture and periapical lesion assessment and TMJ assessment.

Implantology

3D images accurately show the patient's anatomy

- Evaluate bone volume and quality
- Identify and mark anatomical obstacles (mandibular canal, sinus)
- Take precise measurements
- Work in 1:1 "true-to-life" scale
- Plan implants using the Kodak 3D module

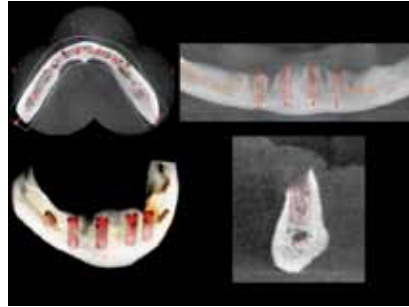

3D imaging allows you to evaluate bone volume, locate vital structures, and work in a 1:1 "true-to-life" scale for better implant planning.

Endodontics

Obtain extraordinary detail at low exposure levels

- Precisely examine root anatomy (curvature, length, number of roots)
- Enhance early diagnosis of endodontic lesions
- Identify anatomical elements in region of interest
- Define endodontic surgical protocol

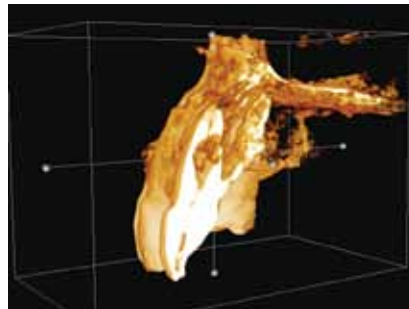

Three-dimensional views show the full extent of inflammatory root resorption in the midroot portion of the canal that extends palatally.

2D imaging can be limited in its ability to give key information needed to adequately assess the canal morphology prior to treatment.



3D image with a 76 micron axial slice clearly reveals three canals in the mesial root of the lower left first molar.

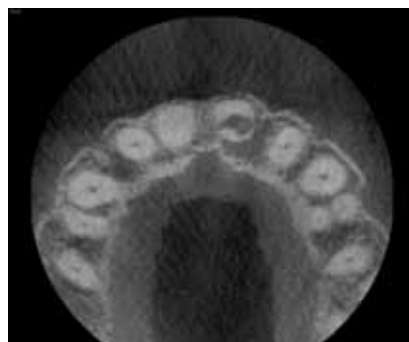

Surgery

Prepare with complete precision

- Identify relation between impacted teeth and organs to protect
- Visualize cysts and periapical lesions
- Define surgical protocol for impacted teeth extraction, cyst removal or periapical lesion treatment

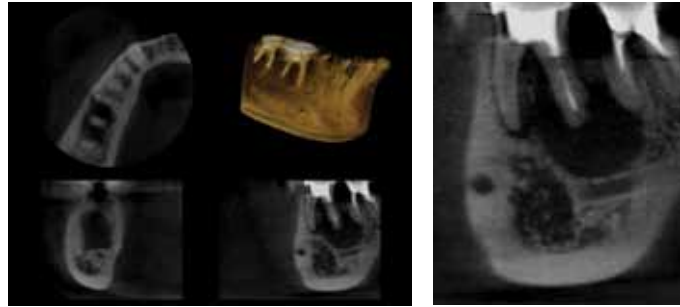

3D image with a 76 micron axial slice reveals the endodontic origin of the cyst on this canine.

Diagnosis

Work in complete confidence

- Identify impacted or misplaced teeth
- Single out fractures and periapical lesions
- Visualize hard tissues of the TMJ

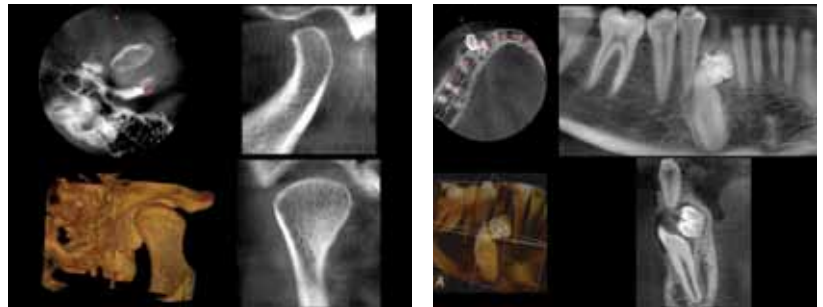

TMJ exam provides clear views of the condyle.

3D image simplifies complex diagnosis such as odontoma.

Orthodontics

Complement your cephalometric and panoramic imaging

- Diagnose complex impactions, supernumeraries, tooth anomalies
- Assess incisor alveolar bone
- Visualize TMJ
- Assess and plan temporary anchorage devices (TADS)

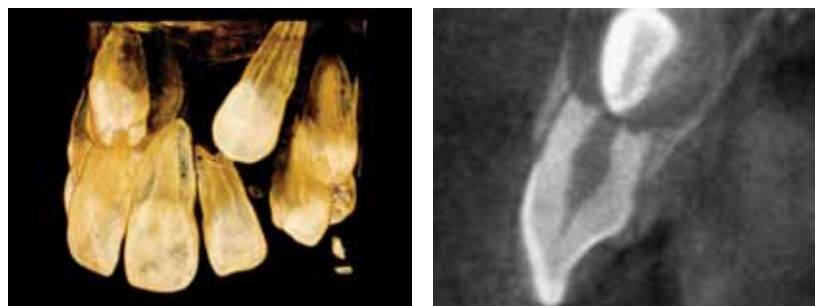

Easily evaluate the presence of supernumerary teeth and their position relative to adjacent teeth with anatomical accuracy, as well as identify any pathology associated with the impaction.

Simple software for a simple solution

Flexible and functional

The Kodak 9000 3D system is equipped with comprehensive dental imaging software, performing both 2D and 3D imaging. Its 3D module is versatile, easy to use, and effective, integrating all the essential functions: measurement, multiplanar review, 3D volume review, and orthogonal viewing to name but a few.

Implant planning module

The software comes standard with an implant planning module to identify exact implant placement, to take measurements (both distances and angles), and to mark the mandibular canal. It also allows you to choose the size and shape of implants in order to create a simulation that's as close to reality as possible.

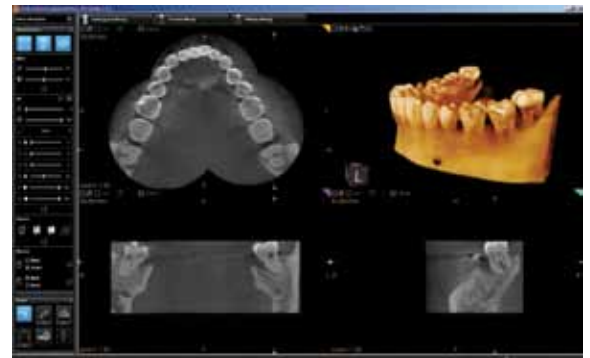

The Kodak 3D imaging module is a feature-rich software that makes easy image review and treatment planning.



Easily manage your favorite implants using our integrated implant library, which includes up-to-date information from the key international manufacturers.

Simplified collaboration

Easy sharing

The Kodak 9000 3D system generates DICOM format images, the international standard for medical images. Volumes can therefore be exported to any DICOM compatible other software for implant placement or treatment planning. Similarly, the Kodak 9000 3D system software can import DICOM images from other 3D systems. To further simplify sharing of results, you can also easily make print-outs and screen captures that are effortlessly managed and transmitted.

Easy integration

As the system is controlled by the same Kodak dental imaging software used for all of your Kodak digital imaging systems, it's easy to learn to operate and simple to integrate into your practice. You'll save time and gain in productivity.

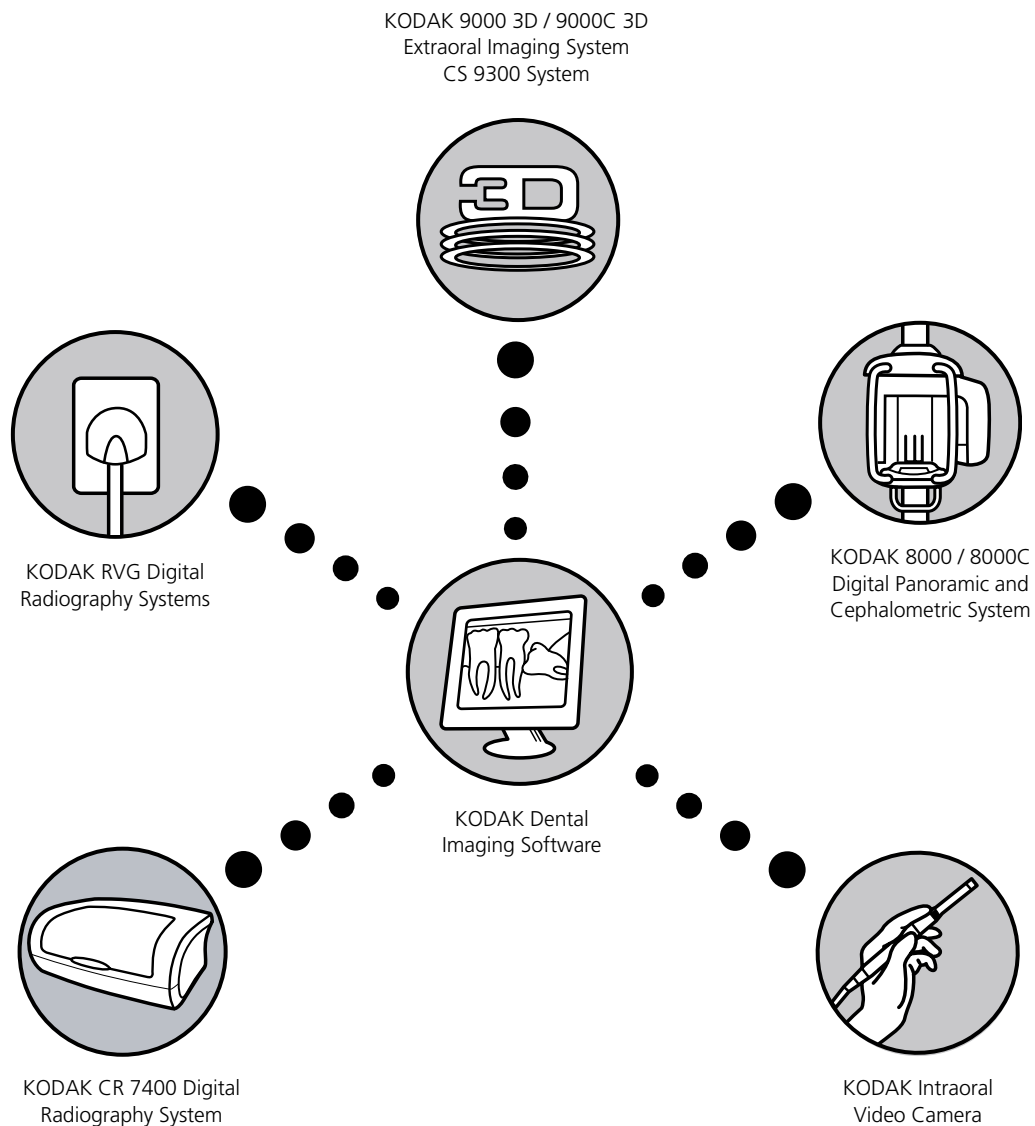



High performance panoramic technology

The panoramic examination is an indispensable first step for the overwhelming majority of dental treatments. It maintains its diagnostic usefulness even when combined with 3D imaging.

The Kodak 9000 system is the true high performance digital panoramic unit. It boasts the same user-friendliness that made its predecessor a success, in addition to an array of new high-end features for greater flexibility and improved efficiency. The Kodak 9000 panoramic system can be upgraded to 3D and cephalometric at a later date if so desired.

High-tech, low strain

Easy and precise positioning

The chief cause of panoramic exam failure is incorrect patient positioning. The Kodak 9000 system employs the same face-to-face arrangement that was so successful in previous Kodak panoramic units. It facilitates proper positioning, thereby reducing the risk of retakes.

Two laser beams help adjust the patient appropriately: the Frankfurt plane and the sagittal median plane. The chin rest, lateral holders and bite block then ensure patient stability.

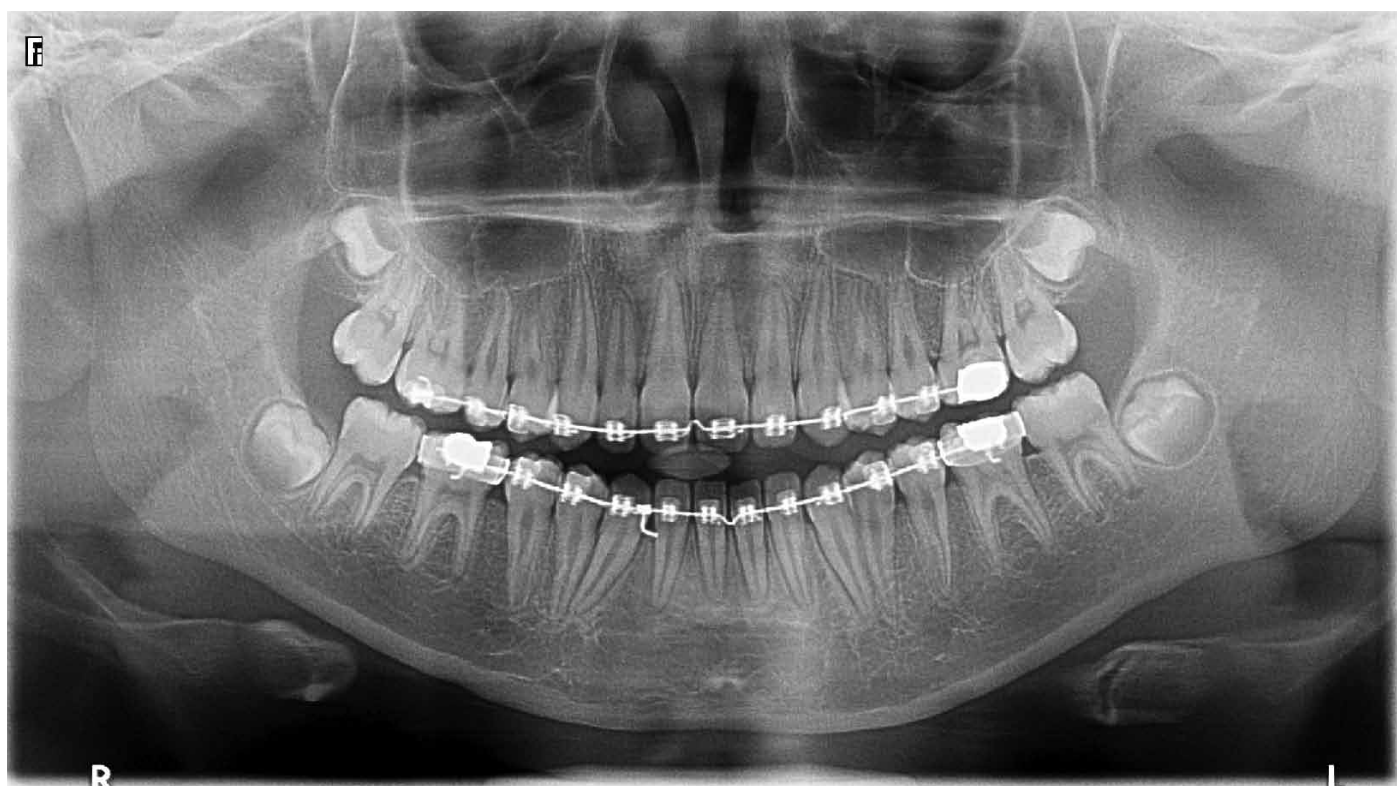

High grade results

Traditional, yet innovative

The 3D component is not the only change to the unit. We also made several improvements to the 2D base system. Hence, the Kodak 9000 system has multiple enhancements, and innovations over previous models.

Fully automated and adjustable

The unit is fully motorized and features an adjustable focal trough. Thus, the system overcomes the difficulties tied to even the most challenging of patient morphologies. In essence, high-end functionalities yield high quality results.

Adjustable focal trough

Because the shape of each jaw is unique, the Kodak 9000 system's focal trough and trajectory change according patient jaw morphology and incisor orientation. The more closely the focal trough follows the jaw, the more accurate the images. In addition,

this function reduces artefacts resulting from undesired objects located outside the focal trough. Of course, the Kodak 9000 system also includes all the other technologies essential to ensuring high quality results: a high frequency generator, a CCD sensor, and spinal shadow compensation.



Focal trough adaptable to jaw morphology, for optimized image quality:



'U', 'V' or Square jaw shape
Large, medium or small jaw size
Standard, inward or outward incisor tilt

Convenient operation

Complete automation for total focus

Thanks to a series of automated programs, the device can minimize the need for operator handling. Program selection occurs directly on the computer through a user-friendly and intuitive interface where settings are pre-programmed. In fact, because sensor selection (panoramic, cephalometric or 3D) is automatic and does not require any handling, you effectively limit the risk of damaging the most sensitive and expensive part of the unit.

Multiple programs covering all 2D diagnosis needs:



Standard panoramic



Child panoramic

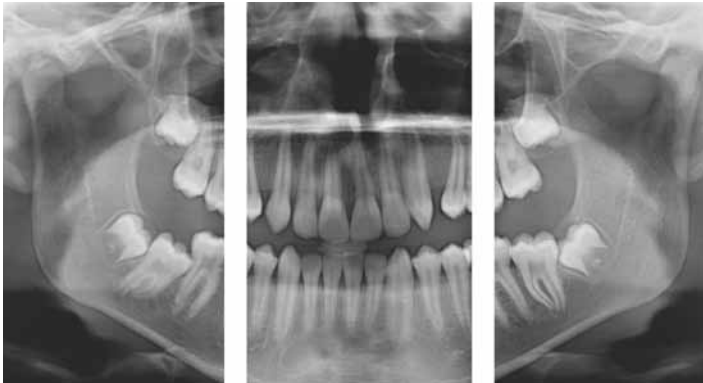

Segmented panoramic

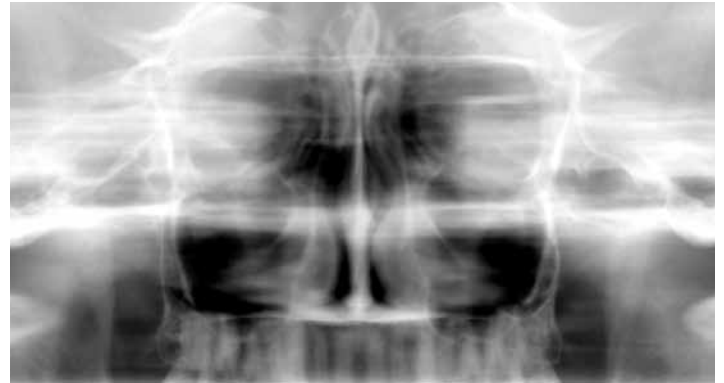

Maxillary sinus



TMJ x4 LA



TMJ x2 LA

Consistently ahead of its time

The new cephalometric module in the Kodak 9000 product portfolio, a third generation optimization of the acclaimed unit, addresses virtually every type of practitioner's needs. It delivers exceptional image quality thanks to exclusive and best in class "one shot" technology. Automatic landmark tracing will boost productivity.

In a way, it's the best of all possible worlds. Orthodontic, maxillofacial surgery and multi-disciplinary practices can benefit from state-of-the-art cephalometric imaging that is at the heart of their care, while adding, complementary and innovative 3D imaging technology.



Fully flexible imaging

The “one shot” difference

Thanks to its state-of-the-art “one shot” technology, acquisition takes less than a second, thereby reducing exposure time and the risk of retakes due to patient movement. Image quality is optimized thanks to the minimization of image distortion common to cephalometric scan technologies. Put simply, thanks to “one shot” technology you’ll feel like you’re operating a film cephalometric unit, but with all the advantages of digital.

The broadest range of image formats

Thanks to its motorized collimator, the Kodak 9000C system is the only unit on the market to offer as broad a range of cephalometric formats. It suits any orthodontic tracing need, from our exclusive full skull (12x12 in.), to standard (8x10 in.) and small field for lower dose exposures. You can thus limit the exposure zone to patient morphology or to the exam being performed. Furthermore, the system generates lateral, frontal, submento-vertex, oblique and carpus images with constant reproducibility.

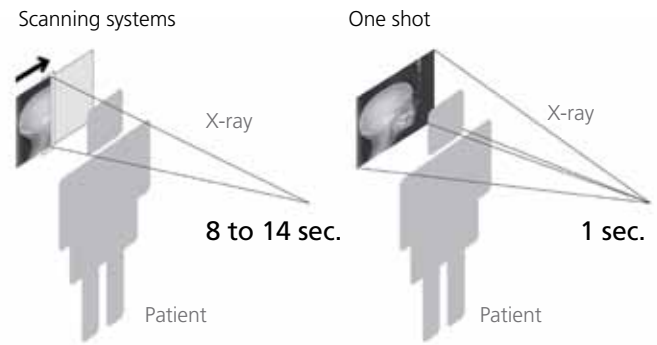

Scanning systems: Require patients to remain immobile 8 to 14 seconds.

“One-shot”: Patients’ craniums are exposed all at once in little more than a second. The result: drastically reduced risk of patient movement and image retakes.

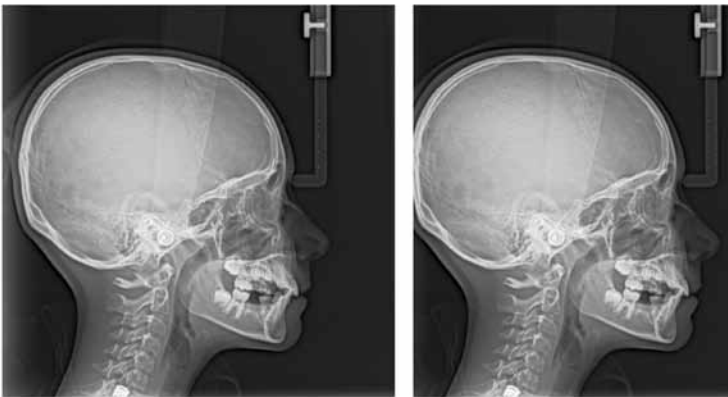

30 x 30 cm (12 x 12 in.)

24 x 30 cm (10 x 12 in.)

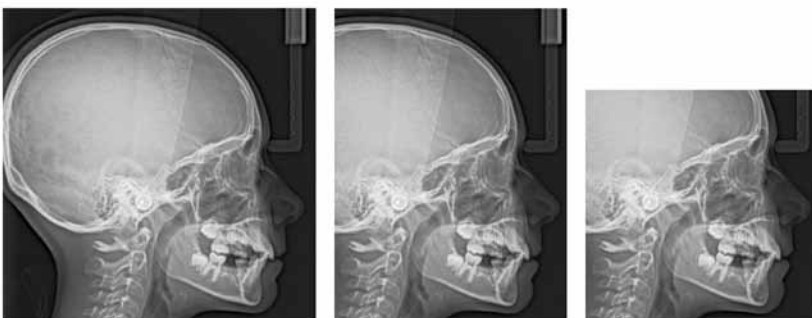

24 x 24 cm (10 x 10 in.)

18 x 24 cm (8 x 10 in.)

18 x 18 cm (8 x 8 in.)

Exclusive automatic tracings

From image to tracings in the blink of an eye

The unit's software is capable of recognizing landmark and anatomical structures and tracing them in less than a minute.* All the time you save allows you to focus on tasks of greater added value. Of course, you can always adjust point positions and tracing afterwards if need be.

Use pre-existing templates or edit your own

The software offers a list of at least thirteen different structures and twenty-six different points, covering the most common analysis needs (Ricketts, McNamara, Steiner, Tweed). The editor allows you to personalize your tracing and to create your own templates. Once created, all you need to do is select the template and the software automatically performs the tracings. Conveniently, the tracings can also be exported to other cephalometric software.



* depending on image format and computer configuration.

Software that makes a difference

Orthodontic pre-set filters

Our uniquely simple and powerful software also features orthodontic pre-set filters that improve image clarity with one click and an automatic filter that outlines soft tissue.



Optimize the visualization of hard and soft tissues using three orthodontic pre-set filters.



Cephalometric programs



Lateral full skull



Frontal PA



Frontal AP

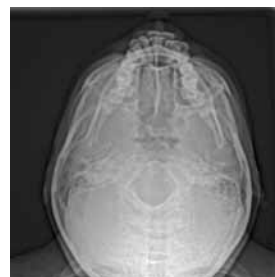

Submento vertex



Carpus

Technical specifications

Tube voltage	60 - 90 kV (max), pulsed mode for 3D modality	
Tube current	2 - 15 mA (max)	
Frequency	140 kHz (max)	
Tube focal spot	0.5 mm (IEC 336)	
Total filtration	> 2.5 mm eq. Al	
3D Modality		
Technology	Digital Volumetric Tomography (DVT)	
Sensor technology	CMOS sensor with optical fibre	
Gray scale	16 bits	
Volume size	50 x 37 mm	
Voxel size	76 x 76 x 76 µm (isotropic voxel)	
Reconstruction time	Depends on the PC, typically under 2 minutes with high performance PC	
Panoramic Modality		
Sensor technology	CCD - Optical fibre sensor	
Gray scale	16384 (14 bits)	
Magnification	1.27	
Exposure time	Depending on program selection. From 4 sec. to 16 sec. Standard Adult: 13.9sec., Standard pediatric: 13.2 sec.	
Programs	12 anatomical settings	
Radiological exam options	<ul style="list-style-type: none"> • Panoramic • Segmented panoramic • Maxillary sinus 	<ul style="list-style-type: none"> • LA TMJ x2 • LA TMJ x4
Input voltage	<ul style="list-style-type: none"> • 230-240 V - 50/60 Hz • 100-110-130 V - 50/60 Hz 	
Cephalometric Modality		
Technology	One shot	
Sensor technology	CCD - Optical fibre sensor	
Gray scale	16384 (14 bits)	
Magnification	1.14	
Exposure time	Standard: under 1 sec., User selectable range: 0.1 - 3.2 sec.	
Cephalometric exam options	<ul style="list-style-type: none"> • Lateral • Oblique • Frontal (AP / PA) 	<ul style="list-style-type: none"> • Submento-vertex • Carpus
Cephalometric formats	18 x 18 cm - 18 x 24 cm - 24 x 24 cm - 24 x 30 cm - 30 x 30 cm	
Weight	Kodak 9000/9000 3D: 160 kg Kodak 9000C/9000C 3D: 199 kg	

Warning: Class 2 laser product. Do not stare into the beam.

Unit dimensions

KODAK 9000 / 9000 3D Systems

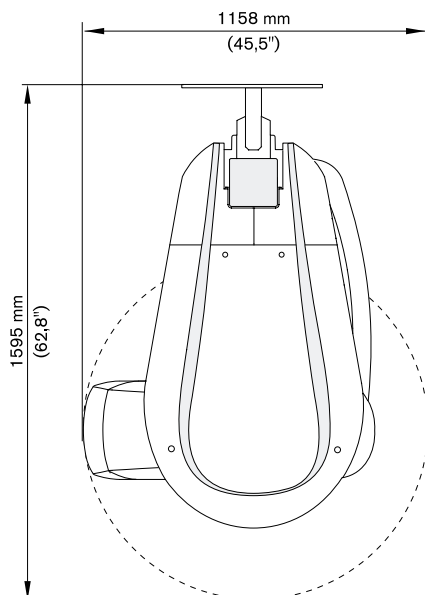
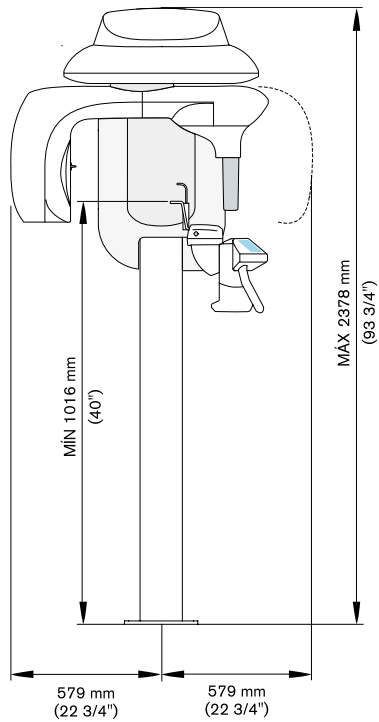

Minimum operational required space*:
Width x depth:
1500 mm (59") x 1700 mm (79").

KODAK 9000C / 9000C 3D Systems

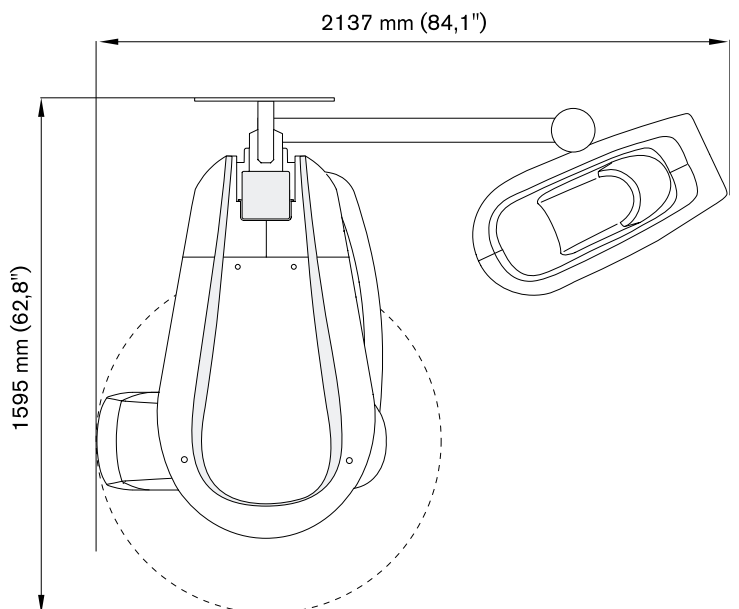
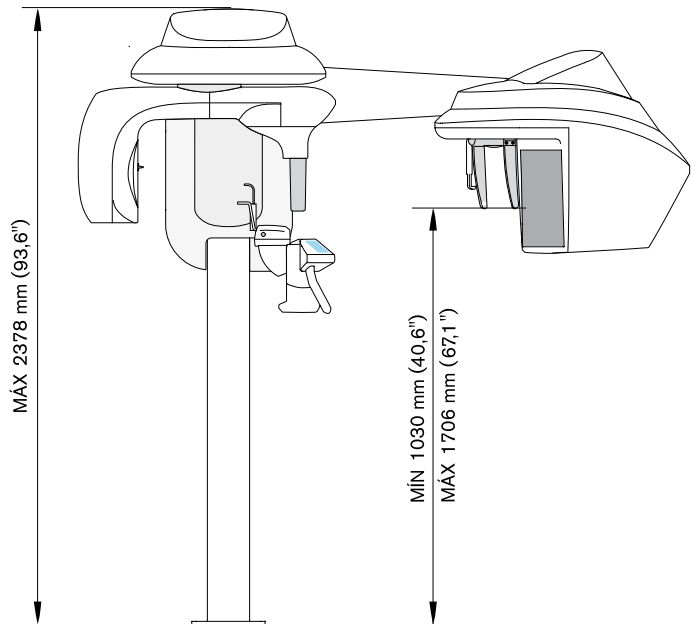

Minimum operational required space*:
Width x depth:
2230 mm (88") x 1700 mm (79").

* refer to local regulatory statements

Would you like to know more?

www.carestreamdental.com

Alternatively, contact your local authorised dealer.

Want to subscribe to our newsletter?

Email dentalnews@carestream.com.

Dealer stamp

Kodak
Licensed Product

Carestream Dental

© Carestream Health, Inc. 2011. RVG is a trademark of Carestream Health.
The Kodak trademark and trade dress are used under license from Kodak.

07.2011